

How to Wire a Bike for Ham Radio

If AA6WK talked you into trying “bicycle-mobile” hamming last month, W8HI has some tips for you on turning your bike into a two-wheeled ham shack.

By: Bill Sharp, W8HI e-mail: tobsharp@earthlink.net

What’s the best way to hook up a ham rig to your bike? What’s the best rig, antenna, etc.? As with anything, there are several “right” ways to do it.

Early on, it’s mostly a matter of personal preference. Where do you want the radio? How do you communicate now? How do you need to communicate? Are you thinking in terms of using the rig mostly for emergencies, or for more frequent conversations, such as what’s common during a net?

Your answers to these questions will influence the specifics of your setup, but there are some fundamentals that apply in all cases:

- *Make it convenient.* If the radio isn’t easy to use, it quickly becomes dangerous. I’ve learned the hard way with a couple of dislocated shoulders and a broken clavicle (collarbone).

- *Make it light.* Anything that goes on the bike just makes it heavier and takes more work to make it go.

- *Make it fixable.* Making something out of nothing is a credo of many hams. It’s how the hobby moves forward in many cases. But when you want something to work, you want it to work, or you want to be able to fix it with parts you can find—in this case, while on the road.

Lessons from GOBA

That said, here’s what I’ve come up with after nine years of research during GOBA (the *Great Ohio Bicycle Adventure*, a family-oriented week-long ride,

*Bill Sharp, W8HI, is Director of Communications for GOBA, the *Great Ohio Bicycle Adventure*. He lives in Delaware, Ohio, when he’s not bicycling around the state.



The author on his “bikemobe” station. Note that his Larsen 1/2-wave antenna is resting on a shelf behind the saddle (seat), so it’s not necessary for him to have a rear carrier on his bike on which to mount the antenna. Just below Bill’s elbow are the power cable and coax leading to his handheld, which is in his rear jersey pocket (and hidden by his arm). The speaker-mic is clipped to his jersey zipper. Finally, the white circle in front of Bill’s sunglasses is a rear view mirror which attaches to his helmet, the mirror and helmet being the two most important safety devices for cycling.

with 3,000 or more riders each year): *The antenna must be a 1/2-wave.* Yes, all savvy hams on 2 meters run 5/8-wave antennas (and the rest of us use 1/4-waves—ed.); however, that’s on a car where there’s a ground plane. On a bike, unless you want to make a ground plane or, more

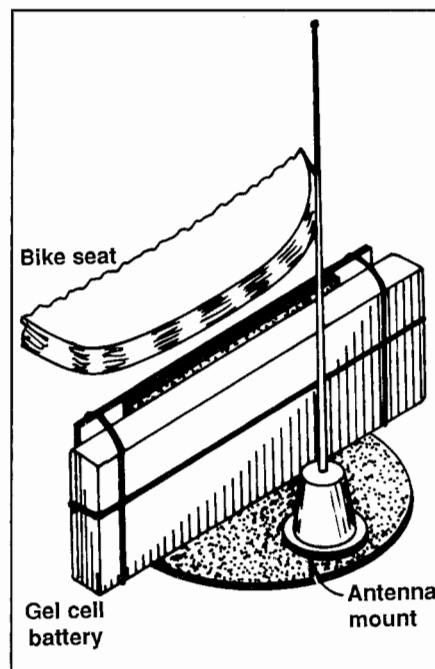

Figure 1. Typical “GOBA” setup for mounting both antenna and battery behind a bicycle seat. The gel-cell battery is mounted with big rubber bands and uses pieces of inner tubes for cushioning between the battery and the shelf.

accurately, a counterpoise, the 1/2-wave is the only way to go. So, find a 1/2-wave antenna you like. On GOBA, we use Larsen’s NMO-mount 1/2-waves (Model No. NMO 150-C-HW), as they’re of the highest quality. But more importantly, all the parts are easily replaceable.

Cables and Connectors

Next comes the cable to connect the antenna to the radio. Because of the properties of a 1/2-wave antenna, it’s necessary to match the antenna to the radio

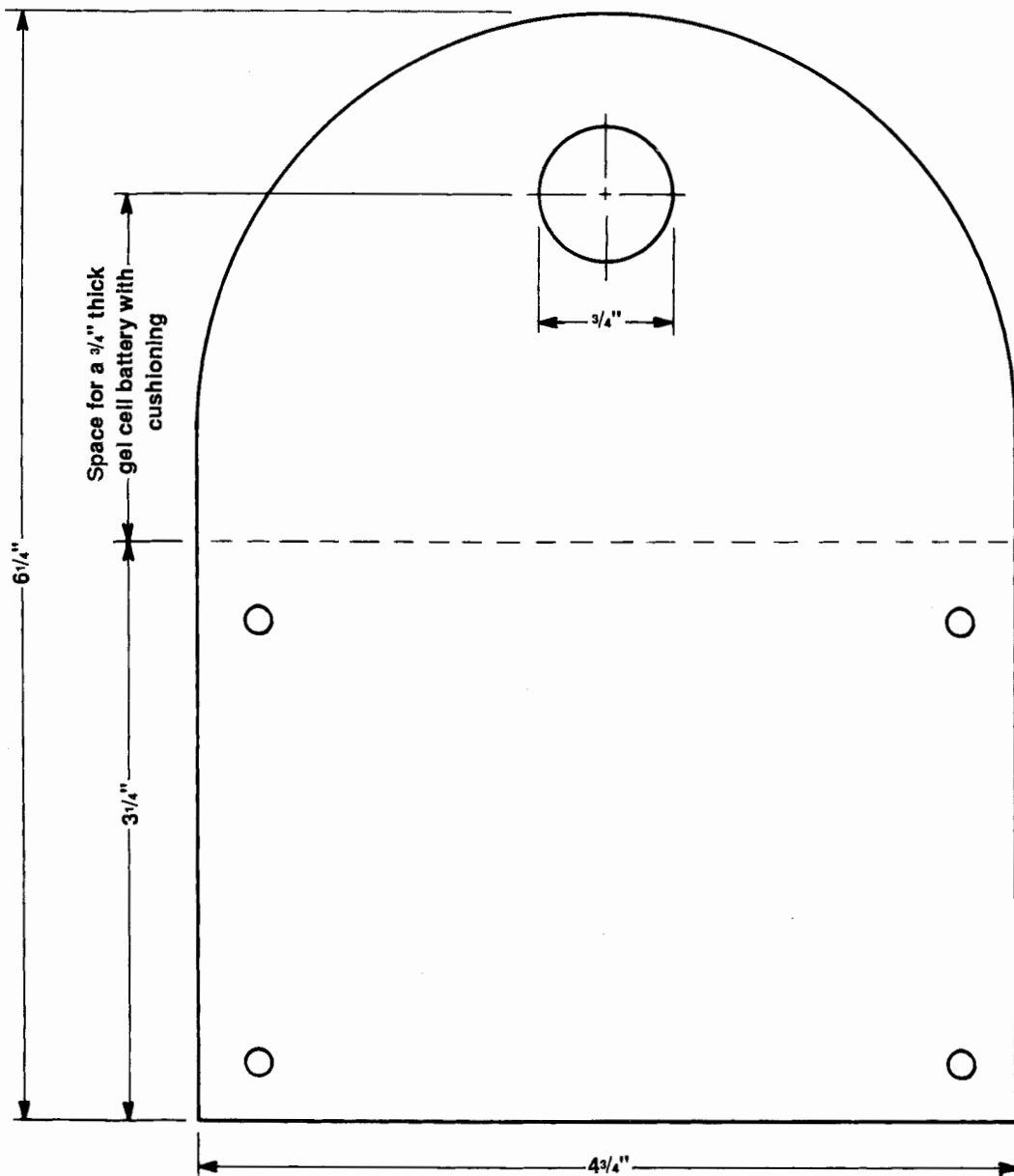

Figure 2. Template for making the GOBA antenna mount from aluminum stock. The $3/4$ -inch hole is to accommodate a Larsen NMO mount. Different mounts may have different requirements.

using an odd multiple of a $1/4$ wavelength. For 2 meters, that's about 57 inches, i.e. three $1/4$ wavelengths. If you want it longer, such as for a tandem bike, then go to five $1/4$ wavelengths. Or, you can call Larsen and order a GBR-1 (three $1/4$

"There are lots of ways to wire a bike for amateur radio, none of which is very difficult or complicated."

wavelengths) or GBR-2 (five $1/4$ wavelengths). They're custom-made for us "bikemobes," or bicycle mobile hams, as Larsen feels it's important to serve the bicycling community in this way.

It's important also that the proper connectors come already installed. Most problems occur in the connectors of any set-up, so if there's any way to reduce the likelihood of failure of your rig on the road, this is it. Get a cable with *factory-installed* connectors. Larsen's GBRs

come with an NMO mount on one end and a BNC on the other. Larsen will accommodate other connectors if you ask. You can also get double shielded cable, again, if you ask.

Mounting Your Antenna

Mounting the antenna on the bike is also a personal thing. Some like to use a telescoping antenna mounted directly to the radio and sticking out of a handlebar

Resources

Half-wave antennas suitable for bike-mounting are available from a variety of manufacturers and dealers, including:

Larsen Electronics, 3611 NE 112 Ave., Vancouver, WA 98682; Phone: (800) 426-1656 ext. 724, ask for Cindee Spickelmier; Fax: (800) 525-6749; Internet: <<http://www.larsenat.com>>.

Gel-cell batteries are also available from a variety of manufacturers and dealers, including:

Advanced Battery Systems (formerly Periphex), 300 Centre St., Holbrook, MA 02343; Phone: (800) 634-8132; Fax: (617) 767-4599.

Batteries Plus, 5010 N. High St., Columbus, OH 43214; Phone: (800) 381-2288, ask for Steve Sutton and let him know that you're calling because of BMHA; Fax: (614) 431-9594; Internet: <<http://www.batteriesplus.com>>.

E.H. Yost & Co. ("Mr. NiCd"), 2211-D Parview Rd., Middleton, WI 53562; Phone: (608) 831-3443; Fax: (608) 831-1082; e-mail: <ehyost@midplains.net>.

Connectors and other small parts are also available from a variety of manufacturers and dealers, including:

Mendelson Electronics (MECI), 340 E. First St., Dayton, OH 45402-1257; Phone: (800) 344-4465; Fax: (800) 344-6324; Internet: <<http://www.meci.com>>.

Mouser Electronics, 958 North Main St., Mansfield, TX 76063; Phone: (800) 992-9943; Fax: (817) 483-0931; Internet: <<http://www.mouser.com>>.

bag. Still others want to mount the antenna on a pannier rack in back, using a small aluminum shelf you can build from aluminum sheeting found in most hardware stores (see Figure 1). Just cut it to size, use tie wraps to hold it on, and drill a $3/4$ -inch hole for the NMO mount.

For GOBA, we use a little shelf, also made from aluminum sheet, which mounts on any dual-water-bottle saddle bracket (just drill the holes appropriately; see Figure 2). It can be either aluminum or plastic. You'll find these bottle holders in triathlete magazines. Profile makes one for two water bottles, as does Minoura. The aluminum shelf mounts on the saddle rails, allowing the antenna to stick out from the back of the saddle (*otherwise known as the "seat"*—ed.).

Power Options

The power source we recommend for GOBA is a 12-volt gel-cell (lead/acid), which will last for a couple of days, even under heavy use. These batteries are available from a variety of sources. One dealer that works closely with BMHA (the Bicycle Mobile Hams of America; see "Why Put a Perfectly Good Ham Rig on a Bicycle?" in last month's issue) is Batteries Plus. Their battery designations are BP2312 (2.3 Ah) and BP2012D (2 Ah). The accompanying charger is their model number TP1250, a 0.5-amp, 15-

volt transformer with a Panasonic connector for the batteries. The Panasonic connector, which you need to solder to the handheld's power cord, is available from Mendelson Electronics, or any of several other supply houses. The battery is held snugly on the aluminum antenna shelf with a heavy-duty rubber band. The power cable, with fuses on each side (both + and -), is coiled along with the coax and tie-wrapped to the appropriate length for convenience.

On to the Radio

After all the ground work is laid, it's time to pay attention to the radio and what goes on in the "cockpit." Here again, with GOBA, because of our need to be in almost constant communication, most of us bikemobe ops prefer a speaker-mic setup. We stash the radio in a plastic bag, which is, in turn, stashed in a jersey pocket (those invaluable pockets in the rear of a bike jersey). The speaker-mic cable comes over or around the shoulder and clips on the front jersey zipper (see Photo).

Because it's a speaker-mic, the non-ham cyclists around us can hear what's going on, and they seem to enjoy the extra safety we bikemobe ops provide. We also prefer speaker-mics to boom mics because we tend to get the boom mic's little ear button soaked with sweat. They're also more cumbersome in an emergency.

Great idea, but perhaps more appropriate in the shack. Another option is to put the rig in a handlebar bag and clip a speaker-mic to the edge of the bag or on the brake cables.

That's About It...

As you can see, there are lots of ways to wire a bike for amateur radio, none of which is very difficult or complicated. You can use any number of antennas. You can run a generator—pedal-powered—rather than batteries. And it really doesn't make much difference where the radio goes as long as it's convenient when you need it. Most of this is a matter of personal convenience. The keys are the antenna—a $1/2$ -wave—and the connecting cable, with well-mounted connectors. For dependability and reliability, especially for emergency use, we at GOBA and the BMHA suggest the Larsen setup. The people at Larsen know about bicycle mobile hamming. They'll understand when you call. On the other hand, as is so often the case with amateur radio, nearly anything will work, as long as it's convenient, lightweight, and fixable. ■

PC HF Facsimile 8.0



For Windows™ \$179.95

SSC is proud to announce PC HF Fax 8.0 for Windows. Now you can receive weather Fax, FEC, RTTY, Morse Code, Navtex, Amtor and Sitor while working with other software. The package comes with our new Windows FSK demodulator, software, manual and database. Just plug it in, connect your receiver, and you are copying the world! Call or write for our FREE Products Catalog.

Visa and MasterCard Welcome

Software Systems Consulting

 615 S. El Camino Real
San Clemente, CA 92672
Tel: 714/498-5784
Fax: 714/498-0568
<http://www.sscorp.com>

CIRCLE 78 ON READER SERVICE CARD